

EF TAPPING SADDLE

04 Update - 05/2024

TECHNICAL DATA

| | |
|-----------------------|-------------------|
| Article No | 001 117 2071 0079 |
| d (mm) | 75 |
| d1 (mm) | 32 |
| le (mm) | 76 |
| h (mm) | 186 |
| h1 (mm) | 56 |
| Z (mm) | 118 |
| L (mm) | 120 |
| Weight (Kg) | 0,610 |
| Box Quantity (pcs) | 15 |
| Box Dimension (cm) | 55x30x37,5 |

INJECTION MOULDED

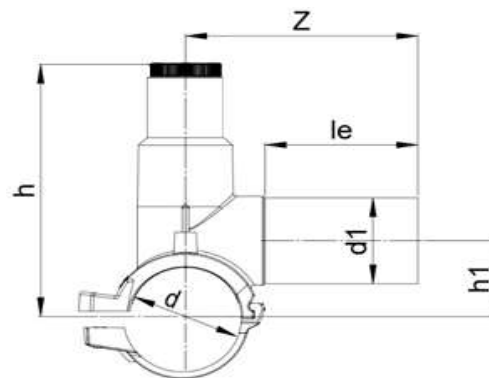

IDENTIFICATION OF PRODUCT

| | |
|----------------|--|
| D(mm) | 75-32 |
| SDR | 11 |
| RAW MATERIAL | PE 100 |
| PRESSURE CLASS | 16 Bar Water 10 Bar Gas |
| TRADEMARK | NTG |
| EXECUTION | Injection Moulded |
| STANDARD | EN 12201-3 EN 1555-3 AS / NZS 4129 |

| | |
|---------------|---|
| SPECIFICATION | Suitable for SDR11....17 pipe Injected monobloc type 4 mm pin connectors Long Fusion outlet Hexagon wrench 17 mm O-ring sealed screw cap |
|---------------|---|

EF SPECIFICATION

| | |
|-----------------|-----------|
| WELDING VOLTAGE | 40 V |
| RESISTANCE | 7,3 Ω |
| WELDING TIME | 75 Sec. |
| COOLING TIME | 15 Min. |
| WINDING TYPE | Monofilar |
| WELDING BARCODE | |



941420321883407305075110

Tolerance on diameters and thickness according to the standards. The other dimensions are specialized. Tolerance $\pm 5\%$. NTG PLASTIK reserves all the right to change any information without giving prior notice. The production, distribution and utilization of this document without explicit authorization is prohibited.